

Integra 1630 option module

Warning: Engineering work should only be performed by qualified, trained personnel abiding by local safety regulations. Do not make modifications or attempt repairs to option modules or other parts of the Integra.

Caution: Upgrade option modules contain static sensitive parts. Do not touch tracks or components on printed circuit board. Ideally work on a static dissipative surface in an anti static environment.

Measurement calibration of the Integra is not affected by replacing the option module providing that the processor/display unit is not opened or modified in any way. Spare screws and fixing kit parts are supplied with the new option module. These are not normally required unless a part is lost during the fitting option.

Profibus option only: The Profibus option includes an enhanced power supply/auxiliary module coupled to the Profibus module. The enhanced power supply/auxiliary module is only designed for use with it's matching Profibus module. The power supply module is not designed to fit to the measurement unit without an interposing Profibus module. Extra long screws are used to secure both enhanced power supply and Profibus modules to the measurement unit.

Read through all of these instructions before starting the fitting operation.

1. Remove the option module from the box.
2. Set aside all screws and other loose parts.
3. Carefully remove the housing and printed circuit board (PCB) from the insert. The PCB may have become unclipped from the housing during transit. If so, visually confirm that no parts have been damaged, check the PCB orientation to ensure that connectors line up with openings in the housing and gently press the PCB back into place. Do not force the assembly – only very light pressure is necessary to engage the PCB in the housing. Apply minimal pressure to a central part of the PCB surface without tracks, using a blunt object or tool that cannot damage the PCB if it slips.

Warning: Ensure power is disconnected from the Integra to be upgraded and that associated CTs are unpowered or shorted. Follow all local regulations and site rules to ensure a safe working environment. Allow 1 minute after disconnecting auxiliary power to allow internal capacitors to discharge to a safe level. Avoid touching the removed PCB or contacting it with metal objects. Shorts across the PCB track work can cause damage, as sufficient residual charge to damage other components remains on capacitors for some hours after removal of auxiliary power.

Instructions for products with top and bottom panel clamps (for products with corner panel clamps see over)

4. Remove any wiring connections from the existing option module.
5. If the Integra is already fitted in a panel, it is possible to replace the option module while the Integra remains in place, providing access is available and the environment is suitable. In this case, continue with step 7. If in doubt, remove the Integra from the panel to an appropriate work area and proceed with step 6.
6. If the Integra is not panel mounted set the Integra face down on a suitable work surface that will not damage the front face of the Integra. Ensure the work area is clear of any waste and small parts that might exert pressure on the display window panels or other case surfaces.
7. Undo the four fixing screws in the corner of the case and withdraw entirely.
8. Remove the existing option module, exerting light pressure on the sides of the case to ensure the PCB remains in place in the housing. Withdraw the module clear of the processing unit. Maintain the plane of the PCB parallel to the rear surface of the processing unit to avoid the risk of damaging pins on the interconnector.
9. Confirm the auxiliary power of the new option module is the same as the old, unless this is intended to be changed.
10. Set the removed option module to one side. It may be stored in the box provided for the new option module and reused in a suitable application if undamaged.
11. Fit the new option module to the processing unit, ensuring that the module is correctly oriented. There is a wide tab on one side of the module and a narrow tab on the other. These mate to corresponding features on the processing unit. Take great care not to misalign the option interconnector pins – these are easy to bend and not covered under warranty if damaged during option module fitting. Again, keep the PCB parallel to the rear face of the processing unit. Only light pressure should be necessary to push the option module home. If it will not push into place easily, remove and inspect to determine the reason.
12. When the option module is in place, refit the 4 corner screws. Tighten to 1.25Nm or 1 ft/lbf only.
13. At this point the Integra may be refitted into the panel, or bench tested using suitable safety precautions.
14. Observing local safety regulations, apply auxiliary voltage. Confirm that the Integra powers up normally and options are functional.

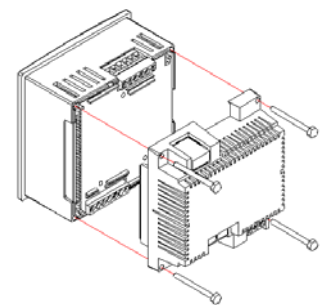

Instructions for products with corner panel clamps

4. Remove any wiring connections from the existing option module.
5. If the Integra is already fitted in a panel, remove the panel clamps. Preferably remove the Integra from the panel, although it is possible to replace the option module while the Integra remains in place.
6. Set the Integra face down on a suitable work surface that will not damage the front face of the Integra. Ensure the work area is clear of any waste and small parts that might exert pressure on the display window panels or other case surfaces.
7. Undo the four fixing screws in the corner of the case and withdraw entirely. Use of a 7mm nut driver is recommended. The nut driver should have a long throat to accommodate the male thread on the top of the screw.
8. Remove the existing option module, exerting light pressure on the sides of the case to ensure the PCB remains in place in the housing. Withdraw the module clear of the processing unit. Maintain the plane of the PCB parallel to the rear surface of the processing unit to avoid the risk of damaging pins on the interconnector.
9. Confirm the auxiliary power of the new option module is the same as the old, unless this is intended to be changed.
10. Set the removed option module to one side. It may be stored in the box provided for the new option module and reused in a suitable application if undamaged.
11. Fit the new option module to the processing unit, ensuring that the module is correctly oriented. There is a wide tab on one side of the module and a narrow tab on the other. These mate to corresponding features on the processing unit. Take great care not to misalign the option interconnector pins – these are easy to bend and not covered under warranty if damaged during option module fitting. Again, keep the PCB parallel to the rear face of the processing unit.
12. Only light pressure should be necessary to push the option module home. If it will not push into place easily, remove and inspect to determine the reason.
13. When the option module is in place, refit the 4 corner screws. Tighten to 1.25Nm or 1 ft/lbf only.
14. At this point the Integra may be refitted into the panel, or bench tested using suitable safety precautions.
15. Observing local safety regulations, apply auxiliary voltage and confirm that Integra powers up as normal and that options are functional.

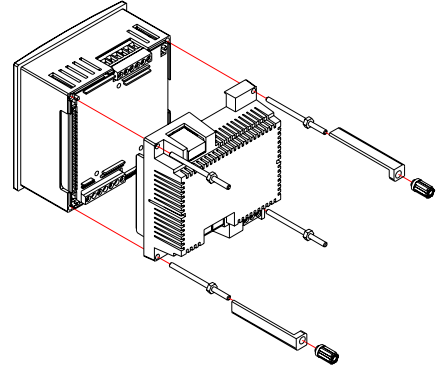

End.

Warning: Engineering work should only be performed by qualified, trained personnel abiding by local safety regulations. Do not make modifications or attempt repairs to option modules or other parts of the Integra.

Warning: Ensure power is disconnected from the Integra to be upgraded and that associated CTs are unpowered or shorted. Follow all local regulations and site rules to ensure a safe working environment. Allow 1 minute after disconnecting auxiliary power to allow internal capacitors to discharge to a safe level. Avoid touching the removed PCB or contacting it with metal objects. Shorts across the PCB track work can cause damage, as sufficient residual charge to damage other components remains on capacitors for some hours after removal of auxiliary power.

Caution: Upgrade option modules contain static sensitive parts. Do not touch tracks or components on printed circuit board. Ideally work on a static dissipative surface in an anti static environment.

All of the above information, including drawings, illustrations and graphic designs, reflects our present understanding and is to the best of our knowledge and belief correct and reliable. Users, however, should independently evaluate the suitability of each product for the desired application. Under no circumstances does this constitute an assurance of any particular quality or performance. Such an assurance is only provided in the context of our product specifications or explicit contractual arrangements. Our liability for these products is set forth in our standard terms and conditions of sale.

TE logo and Tyco Electronics are trademarks. CROMPTON is a trademark of Crompton Parkinson Ltd. and is used by Tyco Electronics under licence.

Tyco Electronics UK Limited
Energy Division
Freebournes Road, Witham, Essex, CM8 3AH, UK
Phone: +44 (0)870 870 7500
Fax: +44 (0)870 240 5287
www.crompton-instruments.com
http://energy.tycoelectronics.com

 **Tyco Electronics**