

Products Covered

077-DI* 077-DP* 077-DW*
 077-DX* 077-DZ* 077KH

* any letter or number

Installation

The product should be panel mounted using the four 1/4" - 28 UNF STUDS and NUTS. Maximum panel thickness 12mm.

Consideration should be given to the space required behind the unit to allow for bends in the connecting cables. Additional protection to the panel may be obtained by the use of an optional gasket. The terminals at the rear of the case should be protected from liquids. Units should be mounted in a reasonably stable ambient temperature and within the range 0-60°C. The unit should not be mounted where it is subjected to excessive direct sunlight, and vibration should be kept to a minimum. Connection wires should be sized to comply to local regulations and should be terminated in tag suitable for the screw connection information and data including type number, input, current, frequency and supply as appropriate. These products do not have internal fuses therefore external fuses **must** be used for safety protection under fault conditions.

Electromagnetic Compatibility

This unit has been designed to provide protection against EM (electro-magnetic) interference in line with requirements of EU and other regulations. Precautions necessary to provide proper operation of this and adjacent equipment will be installation dependent and so the following can only be general guidance:-

- Avoid routing wiring to this unit alongside cables and products that are, or could be, a source of interference.
- The auxiliary supply to the unit should not be subject to excessive interference. In some cases, a supply line filter may be required.
- To protect the product against incorrect operation or permanent damage, surge transients must be controlled. It is good EMC practice to suppress differential surges to 2kV or less at the source. The unit has been designed to automatically recover from typical transients, however in extreme circumstances it may be necessary to temporarily disconnect the auxiliary supply for a period of greater than 5 seconds to restore correct operation.
- Screened communication and small signal leads are recommended and may be required. These and other connecting leads may require the fitting of RF suppression components, such as ferrite absorbers, line filters etc., if RF fields cause problems.

It is good practice to install sensitive electronic instruments that are performing critical functions in EMC enclosures that protect against electrical interference causing a disturbance in function.

MODEL	A	B
077-DI	86	17
Others	132	17

**Analogue Instruments
ANSI Switchboard Meters 070 Series**

Panel Cutout

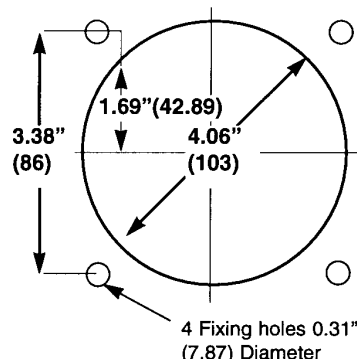

Setting Up And Maintenance

Units are adjusted before despatch and therefore no adjustments are required. During routine servicing and inspection of the associated equipment the unit should be inspected to normal standards for this class of equipment, for example remove accumulations and corrosion.

In the unlikely event of a repair being necessary it is recommended that the unit be returned to the factory or to the nearest Crompton Instruments Service Centre,

Fusing and connections

1. This unit must be fitted with external fuses in voltage supply lines.
2. Voltage input lines must be fused with a quick blow fuse 1A maximum.
3. Choose fuses of a type and with a breaking capacity appropriate to the supply and in accordance with local regulations.
4. Where fitted, CT secondaries must be grounded in accordance with local regulations.

Warning

- During normal operation, voltages hazardous to life may be present at some of the terminals of this unit. Installation and servicing should be performed only by qualified, properly trained personnel' abiding by local regulations. Ensure all supplies are de-energised before attempting connection or other procedures.
- Terminals should not be user accessible after installation and external installation provisions must be sufficient to prevent hazards under fault conditions.
- Never open circuit the secondary winding of an energised current transformer.

INSTALLATION INSTRUCTIONS

Analogue Instruments ANSI Switchboard Meter 070 Series

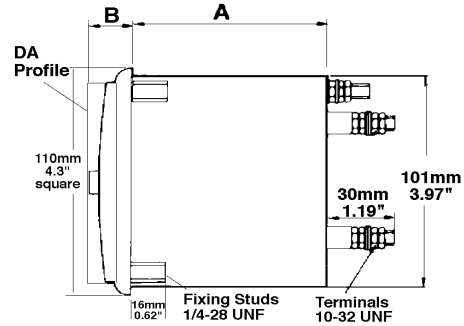

Dimensions

* Indicates any letter or number

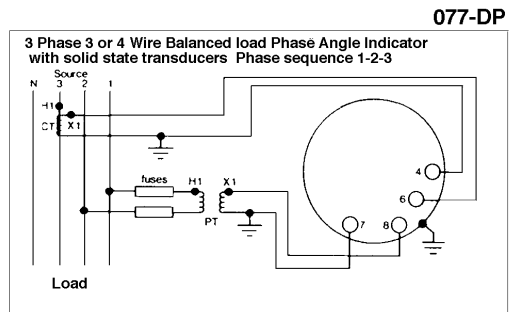
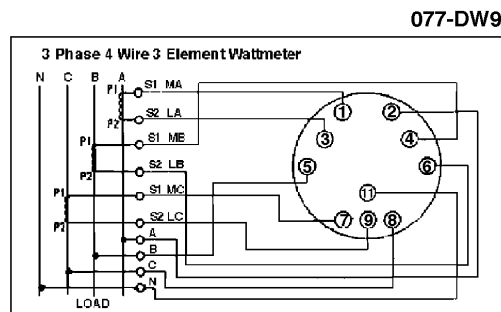
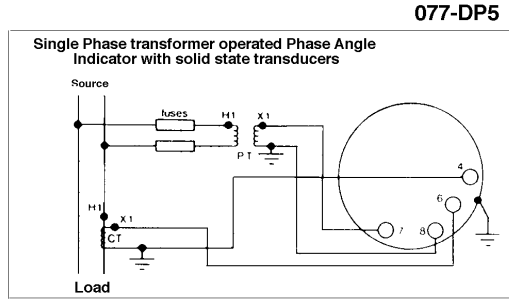
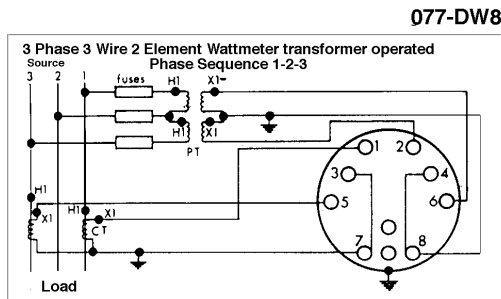
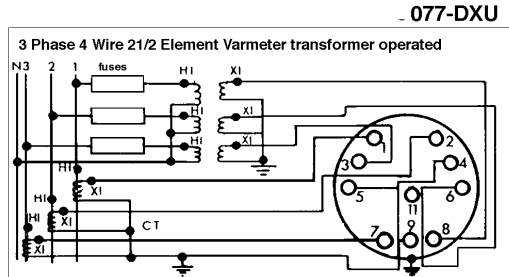
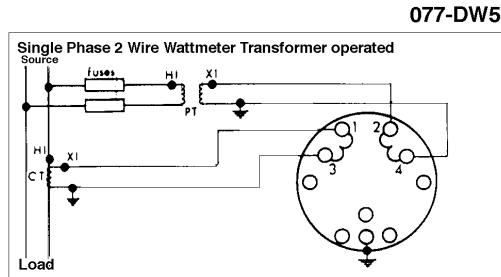
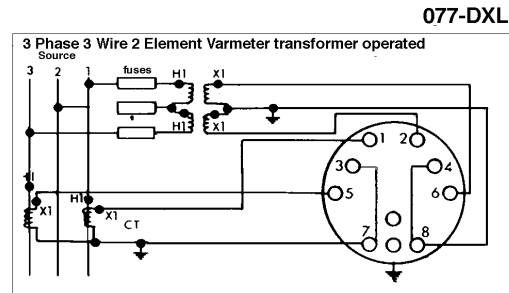
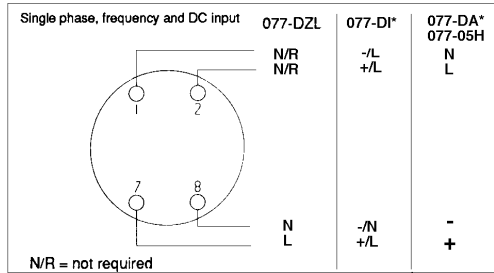

* Ground / Earth via fixing stud

The Information contained in these installation instructions is for use only by installers trained to make electrical power installations and is intended to describe the correct method of installation for this product. However, Tyco Electronics has no control over the field conditions, which influence product installation. It is the user's responsibility to determine the suitability of the installation method in the user's field conditions. Tyco Electronics' only obligations are those in Tyco Electronics' standard Conditions of Sale for this product and in no case will Tyco Electronics be liable for any other incidental, indirect or consequential damages arising from the use or misuse of the products. Crompton is a trade mark.



Tyco Electronics UK Limited
Crompton Instruments
 Freebournes Road, Witham, Essex, CM8 3AH, UK
 Phone: +44 1376 509 509 Fax: +44 1376 509 511

<http://energy.tycoelectronics.com>

Page 1 of 2

Ref: IWYSNC – Rev 6 – Sept 02

Products Covered

Model	Description
244-14A)	Single Phase or 3 phase 3/4 Wire LED
077-14A)	- synchroscope
244-14L)	Single Phase or 3 phase 3/4 wire LED
077-14L)	- Synchroscope and Synchro check relay
244-14G)	244-14L with voltage difference input range
244-14H)	244-14D with voltage difference input range
244-14D)	Single phase or 3-phase 3/4 wire LED
077-14D)	- Synchroscope and Synchro check relay with deadbus

Introduction

244 models may be mounted in a panel of any thickness up to a maximum of 12mm. Mounting is by two clamps and thumbscrews.

077 Models may be mounted in a panel thickness up to a maximum of 8mm (5/16"). Mounting is by 4 x 1/4 - 28 UNF studs and nuts.

For all models consideration should be given to the space required behind the units to allow for bends in the connecting cables. Additional protection to the panel may be obtained by the use of an optional gasket. The terminals at the rear of the case should be protected from liquids. Units should be mounted in a reasonably stable ambient temperature and in any event where the temperature is within the range 0-60 °C.

The unit should not be mounted where it is subjected to excessive direct sunlight; vibration should be kept to a minimum. Connection wires should be sized to comply to local regulations and should be terminated in tags suitable for the crew connections provided, labels are fixed to the units and carry full connection information and data including type number, input voltage, current, frequency and supply as appropriate. The products do not have internal fuses therefore external fuses **must** be used for safety protection under fault conditions.

Fusing and connections

1. This unit must be fitted with external fuses in voltage supply lines.
2. Voltage input lines must be fused with a quick blow fuse 1A maximum.
3. Choose fuses of a type and with a breaking capacity appropriate to the supply and in accordance with local regulations.

Warning

- During normal operation, voltages hazardous to life may be present at some of the terminals of this unit. Installation and servicing should be performed only by qualified, properly trained personnel' abiding by local regulations. Ensure all supplies are de-energised before attempting connection or other procedures.

Analogue Instruments

DIN Instruments 240 Series & ANSI

Switchboard Meters 070 Series

LED Synchroscope & Synchrocheck

Relay with Dead Bus

- It is recommended adjustments be made with the supplies de-energised, but if this is not possible, then extreme caution should be exercised.
- Terminals should not be user accessible after installation and external installation provisions must be sufficient to prevent hazards under fault conditions.
- This unit is not intended to function as part of a system providing the sole means of fault protection - good engineering practice dictates that any critical function be protected by at least two independent and diverse means.

Screw torque

Main terminal screws should be tightened to 1.35Nm or 1.0 ft/lbf only. Detachable terminal connector screws should be tightened to 0.9Nm or 0.7 ft/lbf only. Where fitted, terminal covers are held in place by miniature self tapping screws into plastic. These screws should be tightened by hand only, sufficiently to secure the terminal cover and prevent it vibrating.

Electromagnetic Compatibility

This unit has been designed to provide protection against EM (electro-magnetic) interference in line with requirements of EU and other regulations. Precautions necessary to provide proper operation of this and adjacent equipment will be installation dependent and so the following can only be general guidance:-

- Avoid routing wiring to this unit alongside cables and products that are, or could be, a source of interference.
- The auxiliary supply to the unit should not be subject to excessive interference. In some cases, a supply line filter may be required.
- To protect the product against incorrect operation or permanent damage, surge transients must be controlled. It is good EMC practice to suppress differential surges to 2kV or less at the source. The unit has been designed to automatically recover from typical transients, however in extreme circumstances it may be necessary to temporarily disconnect the auxiliary supply for a period of greater than 5 seconds to restore correct operation.
- Screened communication and small signal leads are recommended and may be required. These and other connecting leads may require the fitting of RF suppression components, such as ferrite absorbers, line filters etc., if RF fields cause problems.

It is good practice to install sensitive electronic instruments that are performing critical functions in EMC enclosures that protect against electrical interference causing a disturbance in function.

Setting Up and Maintenance

Units are adjusted before despatch and therefore no adjustments are required. Unless a fault develops, the unit requires little attention. During routine servicing and inspection of the associated equipment, the unit should be inspected to normal standards for this class of equipment. For example remove accumulations of dust and check all connections for tightness and corrosion. In the event of a repair being necessary, it is recommended that the unit be returned to the factory or to the nearest Crompton Instruments Service Centre, (details on page 2). Should repair be attempted then replacement components must be of the same type, rating and tolerance as those used in the original circuit. It is important that should calibration be deemed necessary, say after repair, then this should only be attempted if the required high accuracy equipment is available. With any enquiry please quote the full model number found on the side of the label. The unit must be recalibrated after repair.

The operation as a Synchroscope

The 244-14A and 077-14A synchrosopes provide illuminated indication of the actual phase difference between the generator GEN voltages and the busbar voltage. If the LED display rotates clockwise the generator frequency is too high and must be reduced and visa versa if the LED display turns anticlockwise.

The operation as synchrocheck relay

The 244-14L/G and 077-14L synchrosopes are based on a microcontroller, which interprets the input signals and displays the phase and voltage information on a series of light emitting diodes (LED's).

Twenty four red LED's are arranged in a ring simulating the traditional 360° analogue movement. Only one LED is lit at any one time indicating the phase difference between the busbar (BUS) and generator (GEN) signals. The unit will operate correctly at any frequency within its range. The voltage levels of the two input signals are continuously measured and compared with the user adjustable voltage difference setting. If the measured difference is outside the allowable range, the ring of LED's will be extinguished and the red GEN LED will be lit. If the voltage difference is within range the green GEN LED will be lit and the ring of LED's will indicate the phase relationship.

Once the BUS and GEN signals become coincident, the unit will wait for an adjustable time delay before lighting the green triangular SYNCHRONISED LEDS and operating the relay. The ring of LED is also extinguished which means the user will only see green LED's when the generator GEN is synchronised with the BUS.

The rear pot adjustments should be set to suit operational requirements.

INSTALLATION INSTRUCTIONS

Analogue Instruments

DIN Instruments 240 Series & ANSI

Switchboard Meters 070 Series

LED Synchroscope & Synchrocheck

Relay with Dead Bus

The Operation as Synchro Check Relay with Dead Bus

Relay Ratings

Single pole changeover 250V, 5A a.c. resistive.

Model 077-14A 360° LED Synchroscope & 360 LED Synchroscope and Synchro Check Relay Models 077-14L/D/G/H

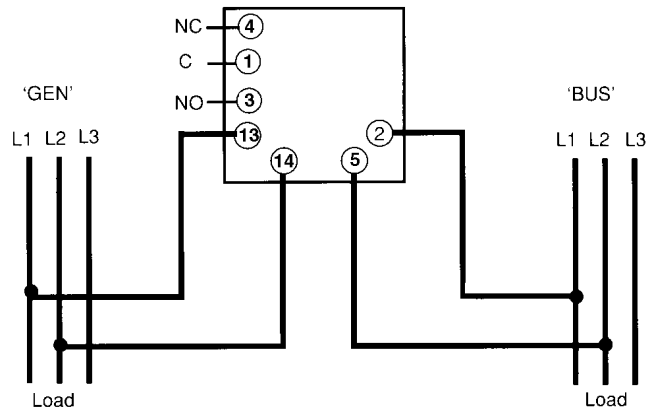

The 244-14D/H and 077-14D operate in the same way as the 244-14L and 077-14L Synchro check relays with the addition of a dead bus option. This optional feature enables the relay to energise with a GEN supply only thus allowing the generator to power the BUS during a supply failure.

Connection Diagrams

Model 244-14A 360° LED Synchroscope & Models 244-LED Synchroscope and Synchro Check Relay Models 244-14L/D/G/H

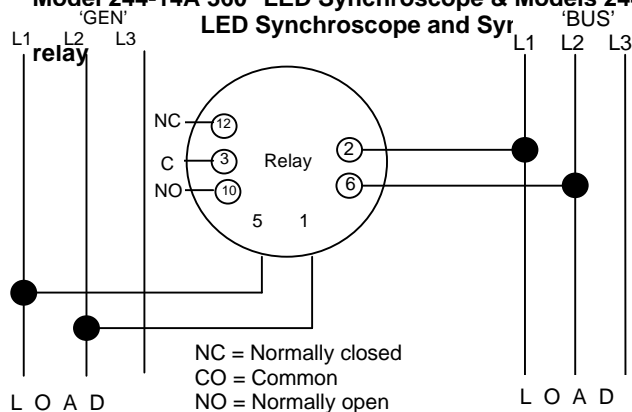

Terminals 3, 10 and 12 are not used on Model 077-14A.

Terminals 1,3 & 4 are not used on Model 244-14A.

NC = Normally closed
CO = Common
NO = Normally open

The Information contained in these installation instructions is for use only by installers trained to make electrical power installations and is intended to describe the correct method of installation for this product. However, Tyco Electronics has no control over the field conditions, which influence product installation. It is the user's responsibility to determine the suitability of the installation method in the user's field conditions. Tyco Electronics' only obligations are those in Tyco Electronics' standard Conditions of Sale for this product and in no case will Tyco Electronics be liable for any other incidental, indirect or consequential damages arising from the use or misuse of the products. Crompton is a trademark.

