

## Quadratic Integra 1530 Digital Metering Systems





Multi function Integra 1530 digital metering systems provide high accuracy <0.2% measurement, display and communication of all major electrical and power quality parameters, including true RMS system values, power quality data and total harmonic distortion (THD) measurement up to the 31st harmonic.

This DIN 96 panel mounted enclosure offers simple programming and display of up to 34 power measurement parameters via a simple menu driven user interface on the front panel. Integra 1530 benefits from optional pulsed, analogue and digital communication outputs, allowing enhanced status information of up to 50 measured parameters to be communicated into building management systems. Additionally, a simple Window based software package is available to remotely configure, monitor and communicate all 50 major electrical and power quality parameters.

## Features

- Measurement and display of up to 34 electrical and power parameters
- Measurement and communication of up to 50 electrical and power parameters
- High contrast red LED display
- LED annunciators for each measured parameter
- THD measurement and power quality data to 31st harmonic
- True RMS measurement
- Pulsed, analogue and digital outputs
- Modbus and Lonworks interface options
- Fully programmable VT and CT ratios
- Industry standard DIN96 case style

## Benefits

- Replaces multiple single function instruments
- Pre-calibrated plug-in options
- High accuracy <0.2%
- Configurable via software package or menu driven interface
- Monitoring, control and protection of expensive power assets

## Applications

- Switchgear
- Distribution systems
- Control panels
- Embedded generation
- Energy management
- Building management
- Utility power monitoring
- Process control
- Motor monitoring

## Approvals

- UL File No. E20300
- UL 61010B-1
- IEC 1010-1/BSEN 61010-1 CAT III

## Operation

The multi function Integra 1530 offers uncomplicated operation and high accuracy <0.2% measurement of three phase voltage, current, frequency, Watts, VAR, VA, energy, power factor, and total harmonic distortion measurement of both phase and system, current and voltage. To suit the requirements of individual power monitoring applications the Integra 1530 offers simple programming and display, via the menu driven interface, or an optional Windows based software configuration package can be used for remote configuration and monitoring. Once configured by either method, simultaneous monitoring of up to 50 electrical and power quality variables can be communicated into building management systems via pulsed, analogue or digital communication options.

If customer requirements extend beyond the original capabilities of their metering, the functionality of this innovative product is easily enhanced to meet new client expectations. Integra pre-calibrated plug-in option cards allow cost effective upgrades with any combination of pulsed, analogue and digital communication outputs. Cards slot simply into the back of the unit, and products do not need to be removed from the installation or recalibrated.

## Accuracy

Integra 1530 digital metering systems utilise true RMS measurement techniques up to the 31st harmonic, providing <0.2% accuracy. An exceptional tolerance to high harmonic frequencies is achieved from a robust frequency detection method, which is able to lock the fundamental frequency onto any phase. High integrity measurements are possible where the system approximates CT current in the absence of voltage signals.

## System Input

Designed for all low, medium and high voltage switchgear and distribution systems, the Integra 1530 offers programmable VT and CT ratio capability. Direct connected up to 480V AC with 5A CT inputs standard, and 1A CT inputs available as an option.

## System Outputs

### Pulsed Outputs

Integra 1530 offers optional single or dual pulsed outputs enabling the retransmission of kW.Hr and kVAR.Hr time based parameters. Outputs are pulsed at a rate proportional to the measured kW.Hr active energy, with pulse width and rate easily programmable either locally or remotely. The output relay has a fully isolated volt free contact, with connection via screw clamp terminals.

### Analogue Outputs

Up to two analogue outputs may also be included, enabling onward transmission of linear parameters using industry standard analogue signalling. Each analogue channel can be assigned to one of 47 measured parameters with the output span fully adjustable to suit customer requirements, and can be configured to operate in normal, reverse, threshold or constant current modes. Both analogue outputs share a common return which is galvanically isolated from non-analogue output terminals.



## Measurement and Display

Up to 34 electrical and power quality parameters can be configured and displayed on the Integra 1530 unit.

- 1 System Volts  
System Current  
System kW
- 2 System Volts THD %  
System Current THD %
- 3 Volts L1 – N (4 wire only)  
Volts L2 – N (4 wire only)  
Volts L3 – N (4 wire only)
- 4 Volts L1 – L2  
Volts L2 – L3  
Volts L3 – L1
- 5 Volts Line 1 THD %  
Volts Line 2 THD %  
Volts Line 3 THD %
- 6 Current L1  
Current L2  
Current L3
- 7 Current Line 1 THD %  
Current Line 2 THD %  
Current Line 3 THD %
- 8 Neutral Current (4 wire only)  
Frequency  
Power Factor
- 9 kVAr  
kVA  
kW
- 10 kW Hr Import (7 digit resolution)
- 11 kVAr Hr Import (7 digit resolution)
- 12 kW Hr Export (7 digit resolution)
- 13 kVAr Hr Export (7 digit resolution)
- 14 kW Demand  
Current Demand
- 15 kW Maximum Demand  
Current Maximum Demand

Enhanced status information of up to 50 measured parameters can be communicated into building management systems via optional pulsed, analogue and digital outputs.

## Digital Communications

### RS485 Modbus RTU

Integra 1530 digital metering systems offer an RS485 communication port for direct connection to SCADA systems using the Modbus RTU protocol, or the Johnson Controls Metasys NII protocol. Remote monitoring enables the user to record the systems parameters in real time, using high resolution numbers. The Modbus protocol establishes the format for the master's query by placing it into the device address. The slave's response is also constructed using the Modbus protocol; it contains the fields confirming the action taken, the data to be returned, and an error-checking field. The Modbus option includes function 8 subfunction 0, which provides return query data diagnostic support, and the ability to change Modbus word order to suit the requirements of the user.

### Lonworks Interface

The Lonworks interface option is designed to conform to the LonMark Interoperability Guidelines version 3.2. This ensures Integra digital metering systems can be integrated into a single control network without requiring custom node or network tool development.

## Software Configuration

Configuration of system parameters, outputs, pulsed relays, current and power demand are easily programmed through a Windows style user interface, which can be installed on any PC running Windows 95, NT or 2000. Communication to Integra 1530 is achieved with a Modbus connection to a COM port on the PC via an RS485/RS232 converter.

The configuration software allows the user to load and save the configuration to and from a hard disk on a PC, and to send and retrieve settings to and from the Integra 1530. Settings can be saved to disk for later use, and can be copied from one Integra to the next.

Status information will usually be communicated into a building management system, but can also be monitored through the configuration software. The software interrogates the selected Integra 1530 every few seconds to obtain data, which can be viewed on a dedicated measurements page.

## Programmable Display

A simple two button interface on the front panel of Integra 1530 units provides simple programming of VT and CT ratio settings, configuration of selected communication options, and adjustment of operating parameters. To prevent unauthorised access to the product configuration settings, all set up screens offer password protection. Once configured, status information can be viewed by scrolling through 15 screens featuring a high contrast 3 line, 4 digit LED display, with separate annunciators for each of the 34 measured parameters. Optional pulsed, analogue or digital outputs allow enhanced status information of up to 50 measured parameters to be communicated into building management systems.

## Programmable Parameters

Parameter	Range
Password:	4 digit 0000 - 9999
Primary Current:	Max 9999:5A (360MW max**)
VT Primary:	400kV (360MW max**)
Secondary Voltage:	Nominal system voltage
	** maximum VT or CT ratios are limited so that the combination of primary voltage and current do not exceed 360MW at 120% of relevant input
Demand Integration Time:	8, 15, 20, 30 minutes
Reset:	Max demand & active energy registers
Pulse Output Duration:	60, 100, 200 ms
Pulse Rate Divisors:	1, 10, 100, 1000
RS485 Interface Baud Rate:	2.4, 4.8, 9.6, 19.2 kB
RS485 Parity:	Odd / Even / No, 1 or 2 stop bits
Modbus Address:	1 - 247
Analogue Outputs:	User definable upper and lower levels and limits





## Specification continued

<b>Enclosure</b>	
Enclosure Style:	DIN 96 panel mount
Compliant With:	UL E20300, UL 61010B-1, IEC 1010-1/ BSEN 61010-1 CAT III, EMC and LVD
Material:	Polycarbonate
Terminals:	Shrouded screw clamp
Dielectric Voltage:	Withstand test 3.25kV RMS 50Hz for 1 minute between all electrical circuits
Operating Temperature:	0 to +55°C
Storage Temperature:	-30 to +80°C
Relative Humidity:	0 .. 90% non condensing
Warm-up Time:	1 minute
Shock:	30g in 3 planes
Vibration:	10 .. 55 Hz, 1g acceleration
IP Protection:	IP54
Dimensions:	96mm wide x 96mm high x 131mm deep (max)
Panel Cut Out:	92mm x 92mm

## Dimensions

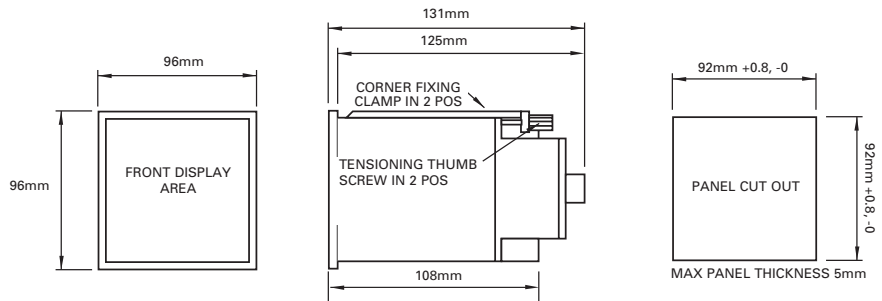

## Wiring

Input connections are made directly to shrouded screw clamp terminals. Terminals for both current and voltage connections are sized to accept two 3mm<sup>2</sup> solid or stranded wires. Connections for auxiliary power, pulsed and analogue options are via screw clamp connectors. Connectors offer retained wire protection leaves suitable for one 2.5mm<sup>2</sup> solid or stranded wire. Digital interface connections are similarly via screw clamp connection, wire protection leaves and sized to accept one 1.5mm<sup>2</sup> solid or stranded wire.

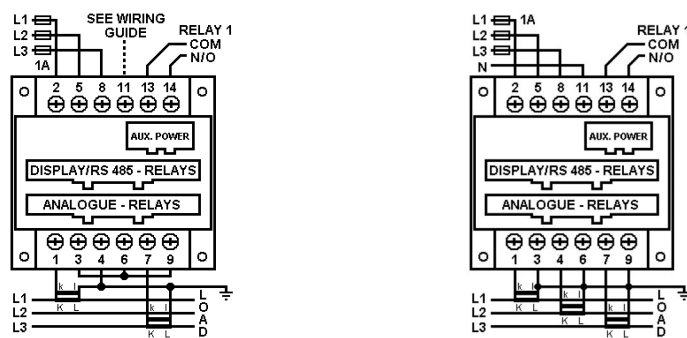

## Auxiliary Supply

The Integra 1530 should ideally be powered from a dedicated supply, either 100 – 250V AC or DC (85V – 280V AC Absolute or 85V – 312V DC Absolute) or 12-48V DC (10.2V – 60V DC Absolute). However the device may be powered from the signal source, provided the source remains within the working range of the chosen auxiliary supply.

## Fusing

It is recommended that all voltage lines be fitted with 1 Amp HRC fuses

## Safety / Ground Connections

For Safety reasons all CT secondary connections should be grounded in accordance with local regulations.



## Order Code Example

### INT-1534-M-5-M-110

Integra 1530 digital metering system, 3 phase 4 wire, nominal input voltage, 140-277V L-N and 241-480V L-L, 5A CT input, auxiliary supply 100 to 250V AC or DC, one relay pulsed output and one RS485 Modbus communication port.

## Ordering Codes

Ordering Code	Product Configuration				
INT-1534-*5-**- option-***	Integra 1530 3 phase 4 wire 5A CT input.				
INT-1533-*5-**- option-***	Integra 1530 3 phase 3 wire 5A CT input.				
<b>Input Voltage Suffix *</b>					
L	100 - 240 V L-L (57.7 - 139V L-N)				
M	241 - 480 V L-L (140 - 277V L-N)				
<b>Auxiliary Supply Suffix **</b>					
L	12 - 48V DC				
M	100 - 250V AC/DC				
<b>Communications Options</b>					
	KWhr Pulsed Output	RS485 Interface Modbus or Johnson Controls Metasys Nil	Lonworks Interface	Analogue Output	
000 - Display Only					
001				1	
002				2	
010		1			
011		1		1	
012		1		2	
030			1		
100	1				
101	1			1	
102	1			2	
110	1	1			
111	1	1		1	
112	1	1		2	
200	2				
201	2			1	
202	2			2	
210	2	1			
211	2	1		1	
212	2	1		2	
<b>Analogue Output Range ***</b>					
0	No output				
1	0-20 mA into <500Ω (user configurable as 4-20 mA)				
2	0-1 mA into <10kΩ				
3	-1/0/+1 mA into <10kΩ				
4	0-5 mA into <2kΩ				
5	-5/0/+5 mA into <2kΩ				
6	0-10 mA into <1kΩ				

## Pre-calibrated plug-in options

The functionality of existing Integra 1530 units can be easily enhanced with the use of Crompton pre-calibrated plug-in cards.

* Specify analogue output range 1-6 as above	KWhr Pulsed Output	RS485 Interface Modbus or Johnson Controls Metasys Nil	Lonworks Interface	Analogue Output	
OPT-1530-001-*				1	
OPT-1530-002-*				2	
OPT-1530-010		1			
OPT-1530-011-*		1		1	
OPT-1530-012-*		1		2	
OPT-1530-030			1		
OPT-1530-200	2				
OPT-1530-201-*	2			1	
OPT-1530-202-*	2			2	
OPT-1530-210	2	1			
OPT-1530-211-*	2	1		1	
OPT-1530-212-*	2	1		2	

Analogue output and Lonworks communication options available Summer 2003.

All of the above information, including drawings, illustrations and graphic designs, reflects our present understanding and is to the best of our knowledge and belief correct and reliable. Users, however, should independently evaluate the suitability of each product for the desired application. Under no circumstances does this constitute an assurance of any particular quality or performance. Such an assurance is only provided in the context of our product specifications or explicit contractual arrangements. Our liability for these products is set forth in our standard terms and conditions of sale. ALR, AMP, AXICOM, B&H, BOWTHORPE EMP, CROMPTON INSTRUMENTS, DORMAN SMITH, DULMISON, GURO, HELLSTERN, LA PRAIRIE, MORLYNN, RAYCHEM, and SIMEL are trademarks.



**Energy Division – a pioneer in the development of economical solutions for the electrical power industry. Our product range includes: Cable accessories, connectors & fittings, electrical equipment, instruments, lighting, insulators & insulation enhancement and surge arresters.**



For more information and your country contact person, please visit us at:  
<http://energy.tycoelectronics.com>



Tyco Electronics UK Limited, Crompton Instruments  
Freebournes Road, Witham, Essex, CM8 3AH, UK  
Phone: ++44 1376 509 509 Fax: ++44 1376 509 511