



User Manual

Integra 1221

Panel Mounted Energy Meter for Single and Three Phase Electrical Systems

Warnings



- During normal operation, voltages hazardous to life may be present at some of the terminals of this unit.
- At voltages below that specified in the Range of Use the meter may shut down. However, voltages hazardous to life may still be present at some of the terminals of this unit.
- Installation and servicing should be performed only by qualified, properly trained personnel abiding by local regulations.
- Ensure all supplies are de-energised before attempting connection or other procedures.
- Terminals should not be user accessible after installation and external installation provisions must be sufficient to prevent hazards under fault conditions.
- This unit is not intended to function as part of a system providing the sole means of fault protection - good engineering practice dictates that any critical function be protected by at least two independent and diverse means.
- The unit does not have internal fuses therefore external fuses must be used for protection and safety under fault conditions.
- Never open-circuit the secondary winding of an energized current transformer.
- This product should only be operated with the CT secondary connections earthed.
- If this equipment is used in a manner not specified by the manufacturer, protection provided by the equipment may be impaired.

1 Introduction

This document provides operating, maintenance and installation instructions. This unit measures and displays the characteristics of Single Phase Two Wire (1P2W), Three Phase Three Wire (3P3W) and Three Phase Four Wire (3P4W) networks. The measuring parameters include Voltage (V), Current (A), Frequency (Hz), Power (kW/KVA/KVAh), Power Factor (PF), Imported, Exported and Total Energy (kWh/kVAh). The unit also measures Maximum Demand Current and Power, this is measured over preset periods of up to 60 minutes. This particular model accommodates 0.1A Current Transformers and can be used with a wide range of CTs. It also comes with a complete communications capability with built in Pulse and RS485 Modbus RTU outputs, configuration is password protected. This product is self-powered from any phase of the supply.

1.1 Unit Characteristics

The Integra 1221 can measure and display:

- Phase to Neutral Voltage and THD% (Total Harmonic Distortion) of all Phases
- Line Frequency
- Current, Maximum Demand Current and Current THD% of all Phases
- Power, Maximum Power Demand and Power Factor
- Imported, Exported & Total Active Energy
- Imported, Exported & Total Reactive Energy

The unit has a Password-Protected set up menu for:

- Changing the Password
- System Configuration - 1P2W, 3P3W, 3P4W.

- Demand Interval Time
- Reset for Demand Measurements
- Pulsed Output Duration

1.2 Current Transformer Primary Current

This unit requires configuring to operate with the appropriate current transformer(s). The secondary current is 0.1A. The CT Primary value should be set according to the CT. It can be used on primary currents up to 9999A. e.g. For a 250/0.1A CT. CT2 = 0.1, CT1 = 250

On the MID Version, you can only program the CT multiplier ONCE.

This cannot be overridden and must be returned to the factory.

1.3 RS485 Serial – Modbus RTU

This unit is compatible with remote monitoring through RS485 Modbus RTU. Set-up screens are provided for configuring the RS485 port.

1.4 Pulsed Outputs

The Integra 1221 has Two Pulsed Outputs. One pulsed output is configurable to active (kWh) or reactive (kVAh) energy. The second pulsed output is fixed to 3200imp/kWh.

2 Start Up Screens

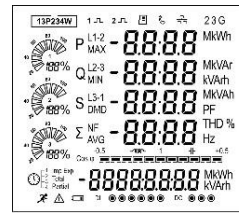

The first screen lights up all display segments and can be used as a display check.

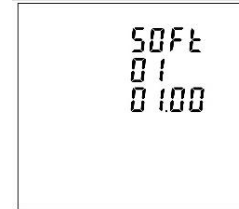

The second screen indicates the firmware installed in the unit and its build number.

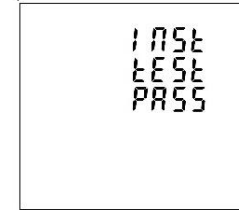

Please note: The numbers on the product may vary from those shown here.

The interface performs a self-test and indicates the result if the test passes.

*After a short delay, the screen will display active energy measurements.

3 Measurements

The buttons operate as follows:



Selects the Power, Voltage, Current, Energy per phase and the system values. In Setup Mode, this is "Escape" (hold 3 sec) button.



Selects the Voltage and Current display screens. In Setup Mode, this is the "Left" (press) button.



Select the Frequency and Power factor display screens. In Setup Mode, this is the "Up" (press) button.



Select the Power display screens. In Setup Mode, this is the "Down" (press) button.



Select the Energy display screens. In Setup mode, this is the "Right" (press) or "Enter" (hold 3 sec) button.

3.1 Phase and System

Each successive press of the button displays the Power, Voltage, Current and Active Energy for each phase. Followed by the Power, Voltage and Current with Reactive Energy per phase.

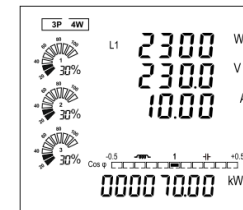

L1 Power, Voltage, Current, Active Energy.



L2 Power, Voltage, Current, Active Energy.

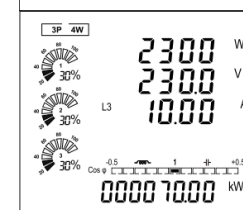

L3 Power, Voltage, Current, Active Energy.

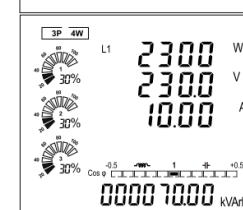

L1 Power, Voltage, Current, Reactive Energy.

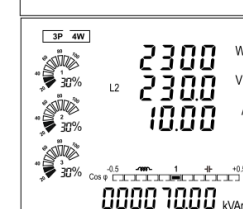

L2 Power, Voltage, Current, Reactive Energy.

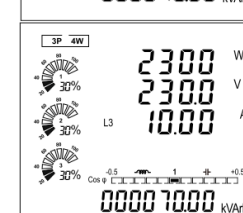

L3 Power, Voltage, Current, Reactive Energy.

3.2 Voltage and Current

Each successive press of the button selects a new parameter.

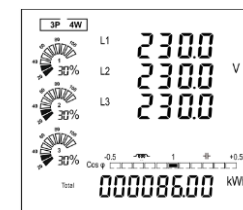

Voltage L-N

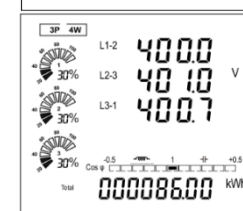

Voltage L-L

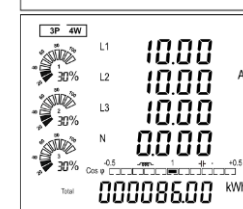

Current on each phase.

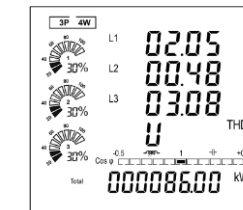

Phase to neutral voltage THD%.



Current THD% for each phase.



Phase Sequence V&I

3.3 Frequency, Power Factor and Demand

Each successive press of the button selects a new range:

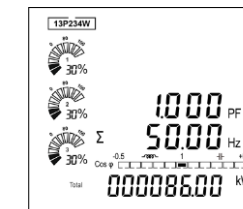

Frequency and Power Factor (total).

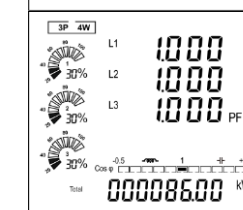

Power Factor of each phase.

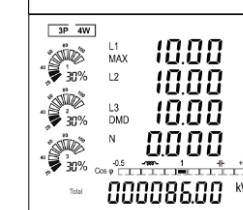

Maximum Current Demand.

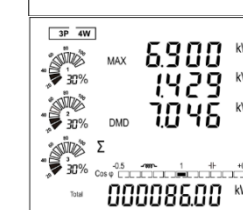

Maximum Power Demand.

3.4 Power

Each successive press of the selects a new range:

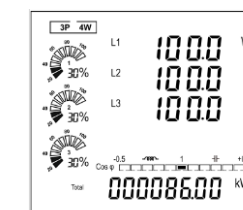

Instantaneous Active Power in kW.

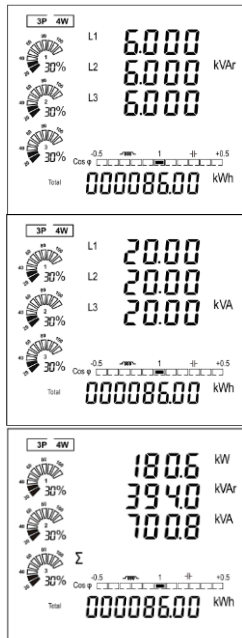

Instantaneous Reactive Power in kVAr.

Instantaneous Volt-Amps in kVA.

Total kW, kVAh, kVA.

3.5 Energy Measurements

Each successive press of the button selects a new range:

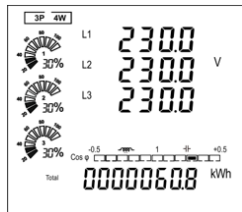

Total active energy in kWh.

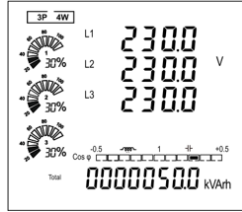

Total reactive energy in kVAh.

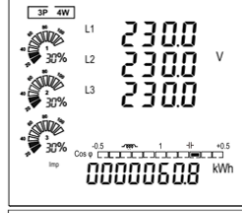

Imported active energy in kWh.



Exported active energy in kWh.



Imported reactive energy in kVAh.



Exported reactive energy in kVAh.

Please note the register is 9999999.9 display over two lines.

4 Setup

To enter set up mode, hold the button for 3 seconds, until the password screen appears.



The setup is password-protected so you must enter the correct password (default '1000') before processing.

If an incorrect password is entered, the display will show: PASS Err (Error).

To exit the set up menu, hold the button for 3 seconds, the measurement screen will display.

4.1 Set up Entry Methods

Some menu items, such as Password and CT, require a four-digit number entry while others, such as supply system, require selection from a number of menu options.

4.1.1 Menu Option Selection

- Use the and buttons to scroll through the different options of the setup menu.
- Hold the button for 3 seconds to confirm your selection.
- If an item flashes, then it can be adjusted by the and buttons.
- Having selected an option from the current layer, hold the button for 3 seconds to confirm your selection.

5. On completion of setting-up, hold the button for 3 seconds, the measurement screen will then be restored.

4.1.2 Number Entry Procedure

When setting up the unit, some screens require the entering of a number. In particular, on entry to the setting up section, a password must be entered. Digits are set individually, from left to right. The procedure is as follows:

- The current digit to be set flashes and then can be adjusted using the and buttons.
- Press the button to move right to the next digit.
- After setting the last digit, hold the button for 3 seconds to save your selection.

4.2 Communication

The RS485 port can be used for communication using Modbus RTU Protocol. Configuring the Modbus settings, such as Address and Baud Rate, is also done within the Password-protected setup menu.

4.2.1 RS485 Address

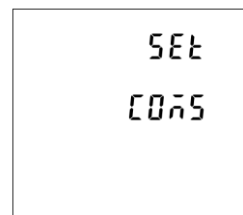

Use the and buttons to select the menu option. The screen will show the current setting.



Hold the button to set the meter Address Range: 001(default) to 247.



Use the and buttons to choose the necessary number, then press the button to move along to the next number.



To save the new setting, hold the button for 3 seconds until the selection stops flashing.

4.2.2 Baud Rate



Use the and buttons to select the menu option. The screen will show the current setting.



Hold the button to enter the menu option, the current selection will flash.

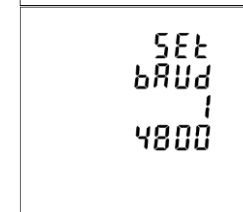

Use the and buttons to select the required option.

On completion of the entry procedure, hold the button to confirm the setting.

4.2.3 Parity



Use the and buttons to select the menu option. The screen will show the current setting.

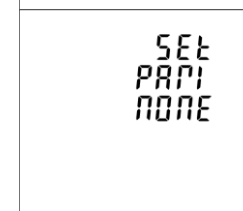

Hold the button to enter the menu option, the current selection will flash.

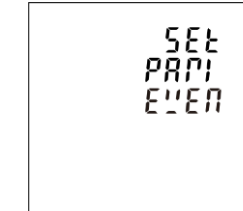

Use the and buttons to select the required option. Range: None (default), Odd or Even.

On completion of the entry procedure, hold the button for 3 seconds until the selection stops flashing.

4.2.4 Stop bits

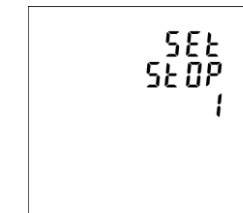

Use the and buttons to select the menu option. The screen will show the current setting.

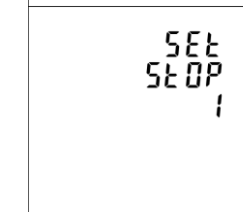

Hold the button to enter the menu option, the current selection will flash.



Use the and buttons to select the required option. Range: 1 (default) or 2.

On completion of the entry procedure, hold the button for 3 seconds until the selection stops flashing.

4.3 CT Configuration

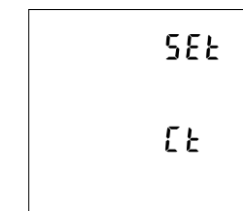

Use the and buttons to select the CT menu option. The screen will show the current setting.

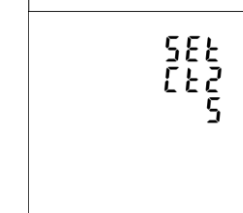

Secondary CT Setting:
Enter the secondary CT menu by pressing the button for 3 seconds.

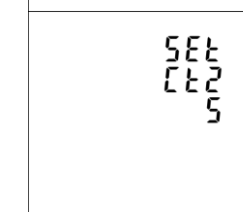

Use the and buttons to select the CT secondary value: 5A (default) or 1A.

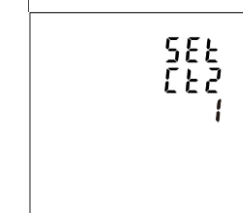

Hold the button for 3 seconds to save the selection.

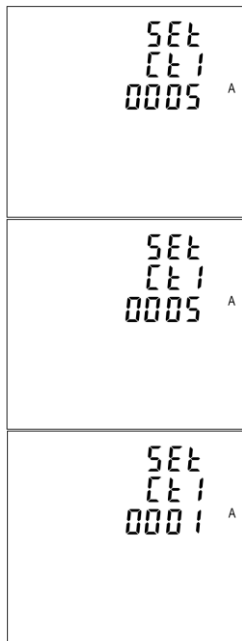

Primary CT Setting:

Enter the primary CT menu by pressing the **E** button for 3 seconds.

Use the **MD PF Hz** and **P** buttons to select the CT value.

Hold the **E** button for 3 seconds to save the selection.

Press **V/A** to exit once complete.

4.4 PT

The PT option sets the Primary Voltage (PT1 100-500000V AC L-N or 100-500000V AC L-L) and the Secondary Voltage (PT2 100-276V AC L-N or 100-480 L-L) of the Voltage Transformer (PT) that may be connected to the meter.

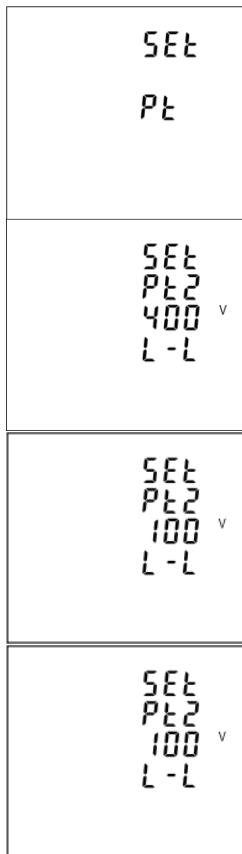

Use the **MD PF Hz** and **P** buttons to select the menu option. The screen will show the current setting. The default value is 230V (1P2W, 3P4W) 400V (3P3W).

Secondary PT Setting:

Hold the **E** button to set the PT secondary option: 100-480V.

Use the **MD PF Hz** and **P** buttons to select the PT secondary value.

Once complete, hold the **E** button for 3 seconds to save.

Press **V/A** to exit once complete.

Note: The unit is able to measure from 57.7V AC L-N however PT2 must be set from 100-276V AC L-N.

4.5 Pulsed Output

Use this section to configure the Pulsed Output Type. Units: kVArh (default); kWh.

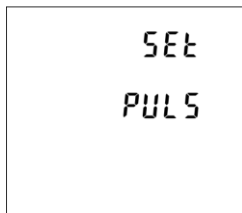

Use the **MD PF Hz** and **P** buttons to select the menu option. The screen will show the current setting.

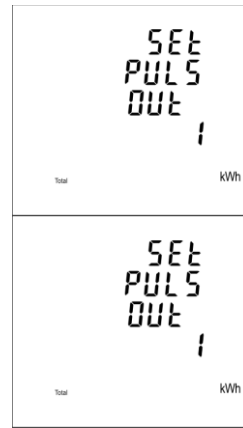

Hold the **E** button to enter the menu option, the current selection will flash.

Use the **MD PF Hz** and **P** buttons to select the required option. Hold the **E** button to confirm the selection.

Once complete, push the **V/A** button to exit the menu.

4.5.1 Pulse Rate

You can configure the number of pulses to relate to a defined amount of Total Energy.

Please note there are limitations that need to be factored in when setting the pulsed output. This is based upon the relay output only being able to pulse 2 times per second.

For example, if the CT is set to 500/5A on a Single Phase network this would generate (500Ax230V=115,000 / 1000) 115kWh which is 31W per second. A setting of 10IMP/kWh (10 pulses per kWh) would generate 3 pulses per second. This will exceed the 2 pulse per second limitation.

Pulse settings: 1 Pulse per: 10W (0.01) / 100W (0.1) / 1000W/1kWh (1) / 10kWh (10) / 100kWh (100) / 1000kWh (1000)

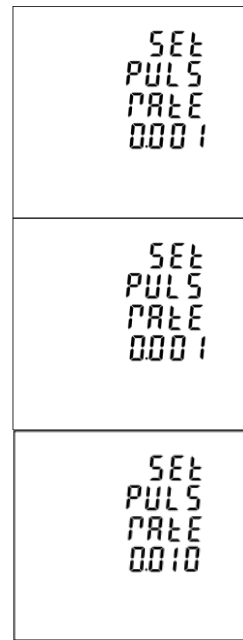

Use the **MD PF Hz** and **P** buttons to select the menu option. The screen will show the current setting.

Hold the **E** button to enter the menu option, the current selection will flash.

Use the **MD PF Hz** and **P** buttons to choose the desired pulse rate.

To save the new setting, hold the **E** button for 3 seconds to save the setting.

4.5.2 Pulse Duration

The energy monitored can be active or reactive and the pulse width can be selected as 200, 100 or 60ms.

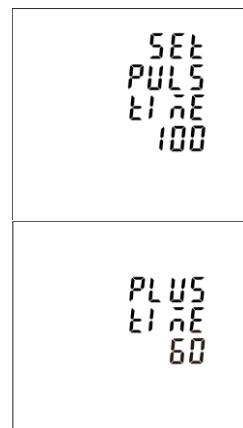

Use the **MD PF Hz** and **P** buttons to choose the desired pulse rate.

To save the new setting, hold the **E** button for 3 seconds.

4.6.1 DIT (Demand Integration Time)

This sets the period (in minutes) in which the Current and Power readings are integrated for maximum demand measurement. The options are 0; 5; 8; 10; 15; 20; 30 or 60 minutes.

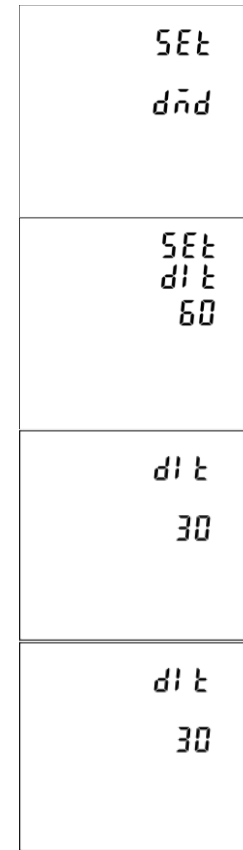

Use the **MD PF Hz** and **P** buttons to select the menu option. The screen will show the current setting.

Hold the **E** button to enter the menu option, the current selection will flash.

Use the **MD PF Hz** and **P** buttons to select the required option.

Hold the **E** button to confirm the selection.

Push the **V/A** button to exit the menu.

4.6.2 Demand Method

Within this menu, you are able to set whether the demand is displayed using a sliding or fixed method.

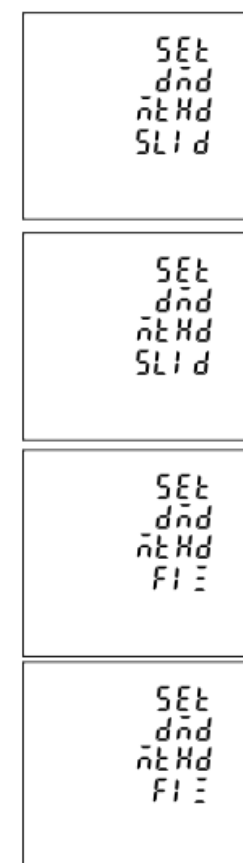

Use the **MD PF Hz** and **P** buttons to select the menu option. The screen will show the current setting.

Hold the **E** button to enter the menu option, the current selection will flash.

Use the **MD PF Hz** and **P** buttons to select the required option.

Hold the **E** button to confirm the selection.

Push the **V/A** button to exit the menu.

4.7.1 Back Light

The back light is a programmable time (in minutes) that determines how long this remains on for before this goes into standby.

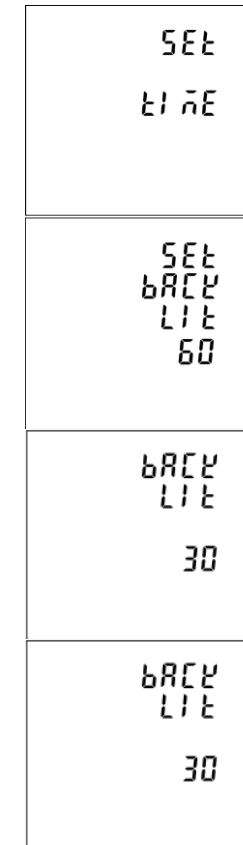

Use the **MD PF Hz** and **P** buttons to select the menu option. The screen will show the current setting.

Hold the **E** button to enter the menu option, the current selection will flash.

Use the **MD PF Hz** and **P** buttons to select the required time.

Hold the **E** button to confirm the selection.

Push the **V/A** button to exit the menu.

4.7.2 Display Scroll

Within this menu, you can determine how long the screen is displayed for before it scrolls to the next screen.

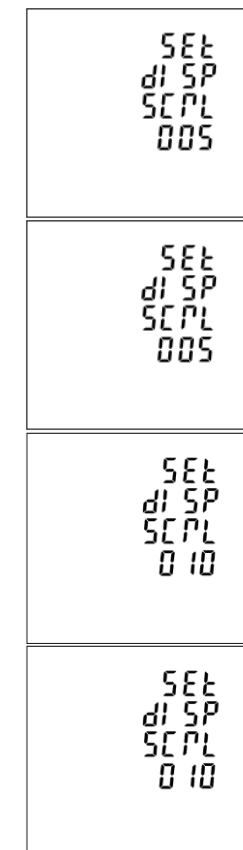

Use the **MD PF Hz** and **P** buttons to select the menu option. The screen will show the current setting.

Hold the **E** button to enter the menu option, the current selection will flash.

Use the **MD PF Hz** and **P** buttons to select the required option.

Hold the **E** button to confirm the selection.

Push the **V/A** button to exit the menu.

4.8.1 Supply System

The unit has a default setting of 3 Phase 4 Wire (3P4W).

Use this section to set the type of electrical system.

Use the and buttons to select the menu option. The screen will show the current setting.

Hold the button to enter the menu option, the current selection will flash.

Use the and buttons to select the required option.

Hold the button to confirm your adjustment.

Press the button to exit.

4.8.2 Auto Scroll

Use this menu to determine whether you would like the display to scroll through the various display screens.

Use the and buttons to select the menu option. The screen will show the current setting.

Hold the button to enter the menu option, the current selection will flash.

Use the and buttons to select the required option.

Hold the button to confirm the selection.

Push the button to exit the menu.

4.9 Reset

The meter provides a function to reset the maximum demand value of current and power.

Use the and buttons to select the menu option. The screen will show the current setting.

Hold the button to enter the menu option, the current selection will flash.

Use the and buttons to select the option you would like to reset.

Hold the button to reset.

Press to return to the main menu.

4.10 Change Password

Use the and to choose the change password option.

Hold the button to enter the set menu. The first digit will start flashing.

Use and to set the first digit and press to move right. The next digit will flash.

Repeat the procedure for the remaining three digits.

After setting the last digit, hold the button to save your selection.

Hold the button to exit the menu.

4.11 CT Reversal

The CT connections can be reversed through the "Set Sys Cnct" menu, choosing between Forward (Frd) or Reversed (Rev) depending on the system.

Use the and buttons to select the menu option. Hold the button to view the sub-menu.

Within this screen, you can change "Forward" to "Reverse" on each individual CT connection.

Hold the button to confirm your adjustment.

You can then move on to IB or IC using the and buttons.

Once complete, hold the button for 3 seconds to exit the setup menu.

5 Specifications

5.1 Measured Parameters

The unit can monitor and display the following parameters of a Single Phase Two Wire (1P2W), Three Phase Three Wire (3P3W) or Three Phase Four Wire (3P4W) system.

5.1.1 Voltage and Current

- Phase to Neutral Voltages 57.7-276V AC (L-N).
- Phase to Phase Voltages 100-480V AC (L-L).
- Percentage Total Voltage Harmonic Distortion (V %THD) for each Phase to Neutral (not for 3P3W supplies).
- Percentage Total Voltage Harmonic Distortion (V% THD) between Phases (3 Phase supplies only).
- Current %THD for each Phase.
- Burden <15VA (nom 2VA)
- Self powered from any phase

5.1.2 Power factor and Frequency and Max. Demand

- Frequency in Hz
- Instantaneous power:
- Power 0-3600 MW
- Reactive power 0-3600 MVAR
- Volt-amps 0-3600 MVA
- Maximum Demand Power since last reset
- Power factor
- Maximum Neutral Demand Current, since the last reset (for 3P4W supplies only)

5.1.3 Energy Measurements

- Imported/Exported active energy 0 to 9999999.9 kWh
- Imported/Exported reactive energy 0 to 9999999.9 kVARh
- Total active energy 0 to 9999999.9 kWh
- Total reactive energy 0 to 9999999.9 kVARh

5.2 Measured Inputs

Voltage inputs through 4-way fixed connector with 2.5mm² stranded wire capacity. Single Phase Two Wire (1P2W), Three Phase Three Wire (3P3W) or Three Phase Four Wire (3P4W) unbalanced. Line frequency measured from L1 Voltage or L3 Voltage. Three current inputs (six physical terminals) with 2.5mm² stranded wire capacity for connection of external CTs. Nominal rated input current 5A or 1A AC RMS.

5.3 Accuracy

- Voltage 0-5% of range maximum
- Current 0-5% of nominal
- Frequency 0-2% of mid-frequency
- Power factor 1% of unity (0.01)
- Active power (W) ±1% of range maximum
- Reactive power (VAR) ±1% of range maximum
- Apparent power (VA) ±1% of range maximum
- Active energy (Wh) Class 1 IEC 62053-21
- Reactive energy (VARh) ±1% of range maximum
- Total harmonic distortion 2% up to 63rd harmonic
- Response time to step input 1s, typical, to >99% of final reading, at 50 Hz.

5.4 Auxiliary Supply

This product is self-powered from any of the three phases.

5.5 Interfaces for External Monitoring

Three interfaces are provided:

- RS485 communication channel that can be programmed for Modbus RTU protocol
- Pulse output 1 indicating real-time measured energy (configurable)
- Pulse output 2 3200IMP/kWh (not configurable)

The Modbus configuration (baud rate etc.) and the pulse relay output assignments (kW/kVARh) are configured through the set-up screens.

5.5.1 Pulse Output

Opto-coupler with potential free SPST-NO Contact (Contact rating 5-27V DC / Max current input: Imin 2mA and Imax 27mA DC). The pulse output can be set to generate pulses to represent kWh or kVARh.

Rate can be set to generate 1 pulse per:

- 0.001 = 1 Wh/VArh
- 0.01 = 10 Wh/VArh
- 1 = 1 kWh/kVARh
- 10 = 10 kWh/kVARh
- 100 = 100 kWh/kVARh
- 1000 = 1000 kWh/kVARh

Pulse width 200/100/60 mS.

5.5.2 RS485 Output for Modbus RTU

For Modbus RTU, the following RS485 communication parameters can be configured from the set-up menu:

Baud rate: 2400, 4800, 9600, 19200, 38400

Parity: none (default) / odd / even

Stop bits: 1 or 2

RS485 Network Address: 3 digit number - 001-247

Modbus™ Word order Hi/Lo byte order is set automatically to normal as defined in IEEE 754. It cannot be configured from the set-up menu.

5.6 Reference Conditions of Influence Quantities

Influence Quantities are variables that affect measurement errors to a minor degree. Accuracy is verified under nominal value (within the specified tolerance) of these conditions.

- Ambient temperature 23°C ±1°C
- Input waveform 50 or 60Hz ±2%
- Input waveform Sinusoidal (distortion factor < 0.005)
- Auxiliary supply voltage Nominal ±1%
- Auxiliary supply frequency Nominal ±1%
- Auxiliary supply waveform (if AC) Sinusoidal (distortion factor < 0.05)
- Magnetic field of external origin Terrestrial flux

5.7 Environment

- Operating temperature -25°C to +55°C*
- Storage temperature -40°C to +70°C*
- Relative humidity 0 to 95%, non-condensing
- Altitude Up to 3000m
- Warm up time 1 minute
- Vibration 10Hz to 50Hz, IEC 60068-2-6, 2g
- Shock 30g in 3 planes

*Maximum operating and storage temperatures are in the context of typical daily and seasonal variation.

5.8 Mechanics

- Enclosure Style DIN 96 panel mount
- Dimensions 96x96x62 mm
- Panel cut-out 92x92mm
- Panel thickness 1-5 mm
- Protection rating Front IP54, Rear IP30
- Material UL 94-VO
- Weight 340 g

6 Installation and Maintenance

6.1 Installation notes

Units should be installed in a dry position, where the ambient temperature is reasonably stable and will not be outside the range -25 to +55°C. Vibration should be kept to a minimum. Preferably, mount the Integra so that the display contrast is not reduced by direct sunlight or other high intensity lighting.

6.2 Input Wiring and Fusing

Voltage lines must be fused with a quick blow AC fuse 1A maximum. Auxiliary supply lines must be fused with a slow blow fuse rated 1A maximum. Choose fuses of a type and with a breaking capacity appropriate to the supply and in accordance with local regulations.

A switch or circuit breaker allowing isolation of supplies to the unit must be provided.

6.3 Wire Size

Voltage and current terminal blocks will accept 0.05mm² to 2.5mm² stranded cable.

6.4 Maintenance

The front of the case should be wiped with a dry cloth only, using minimal pressure. If necessary wipe the rear case with a dry cloth. No user serviceable parts.

7 Declaration of Conformity

We, Tyco Electronics UK Ltd, declare under our sole responsibility as the manufacturer that the poly phase multifunction electrical energy meter "Integra 1221" correspond to the production model described in the EC-type examination certificate and to the requirements of the Directive 2004/22/EC EC type examination certificate number 0120/SGS0251. Identification number of the NB 0120.

8 Dimensions

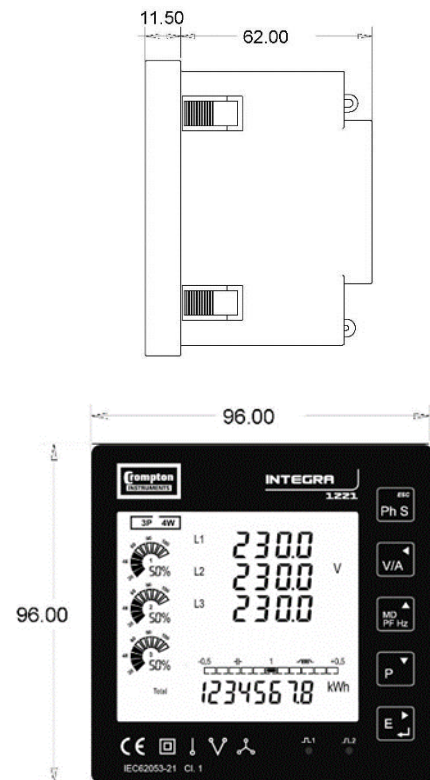

9 Installation

9.1 Single phase two wires

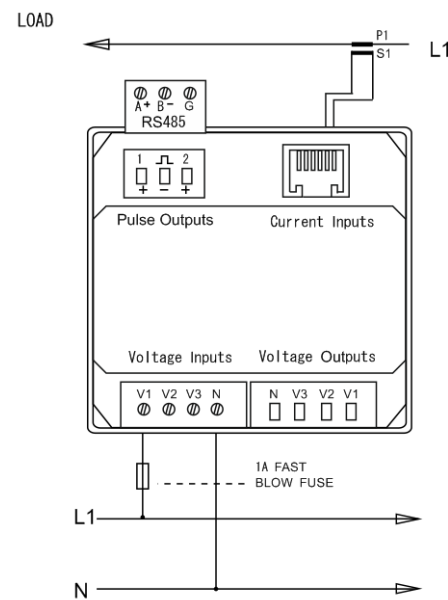

9.2 Three phase three wires

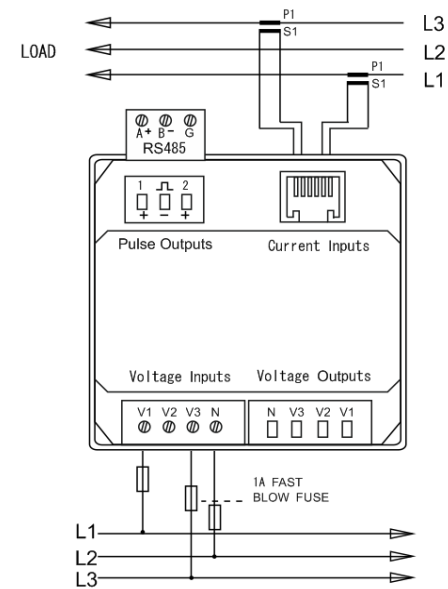

Please note for 3P3W configuration L2 is connected through the neutral and not V2.

9.3 Three phase four wires

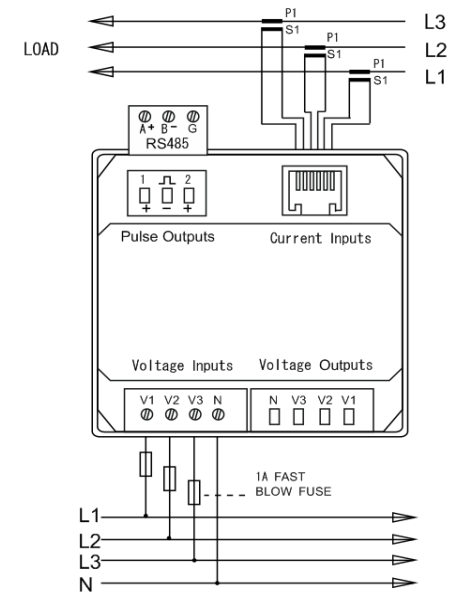

The maximum number of products that can be connect is a single chain is 20 products.

Explanation of Symbols

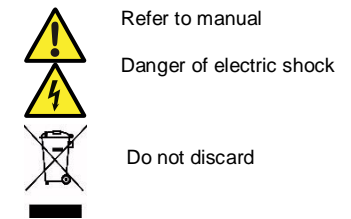

While TE has made every reasonable effort to ensure the accuracy of the information in this catalogue, TE does not guarantee that it is error-free, nor does TE make any other representation, warranty or guarantee that the information is accurate, correct, reliable or current. TE reserves the right to make any adjustments to the information contained herein at any time without notice. TE expressly disclaims all implied warranties regarding the information contained herein, including, but not limited to, any implied warranties of merchantability or fitness for a particular purpose. The dimensions in this catalogue are for reference purposes only and are subject to change without notice. Specifications are subject to change without notice. Consult TE for the latest dimensions and design specifications. TE connectivity (logo), TE (logo) and TE Connectivity are trademarks of the TE Connectivity Ltd. family of companies. Crompton is a trademark of Crompton Parkinson and is used by TE Connectivity under a licence. Other logos, product and company names mentioned herein may be trademarks of their respective owners

TE Energy – innovative and economical solutions for the electrical power industry: cable accessories, connectors & fittings, insulators & insulation, surge arresters, switching equipment, street lighting, power measurement and control.

Tyco Electronics UK Ltd
TE Energy
Freebournes Road
Witham, Essex CM8 3AH
Phone: +44 (0)870 870 7500
Fax: +44 (0)870 240 5289
Email: Crompton.info@te.com
www.crompton-instruments.com

